

HC-49US/SMD 石英晶振
24.000MHZ/20PF/±20PPM

SPECIFICATION REQUIREMENTS FOR CRYSTAL
晶体产品要求
 电气参数 Electrical Characteristic:

1. Model No.	<input type="checkbox"/> HC-49US <input checked="" type="checkbox"/> HC-49US/SMD <input type="checkbox"/> HC-49U <input type="checkbox"/> HC-49USS <input type="checkbox"/> HC-49USS/SMD <input type="checkbox"/> 2×6 <input type="checkbox"/> 3×8 <input type="checkbox"/> 3×9 <input type="checkbox"/> 3×10
2. Nominal Frequency(FR)	24.000MHZ
3. Oscillation Mode	<input checked="" type="checkbox"/> Fundamental 3RD overtone <input type="checkbox"/> 5th overtone
4. Frequency stability(Tol)	± 20ppm(ref. at 25°C)
5. Operation Temperature	-20°C to +70°C
6. Storage Temperature	-40°C to +85°C
7. Temperature Characteristic	± 30ppm
8. Load Capacitance(CL)	20pF
9. Series Resisitance(ESR)	≤ 30 Ω
10. Drive Level	100uW
11. Shunt Capacitance (Co)	≤ 5pF Max (Or PF~ PF)
12. Aging Rate Per Year	± 3ppm/year
13. Insulation Resistance	500M Ω min.at DC 100V ± 10V
14 Test Circuit.	Measured by S&A 250B

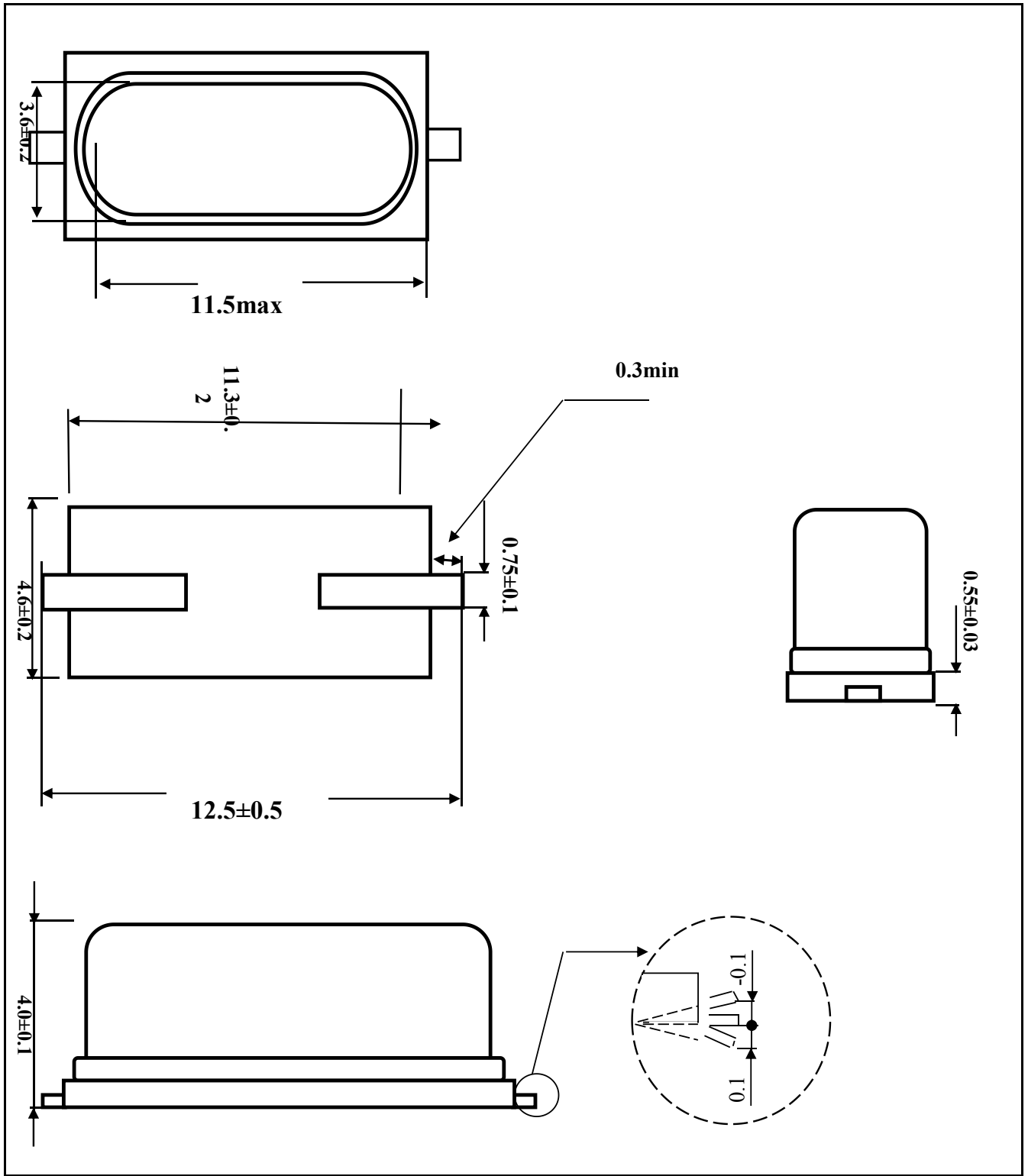

FREQUENCY SPEC	HOLDER	HC-49US/ SMD	ENGINEER	APPROVED
	TYPE			
	DIMENSION	mm		
	SCALE	5:1		

可靠性实验规范 RELIABILITY SPECIFICATION

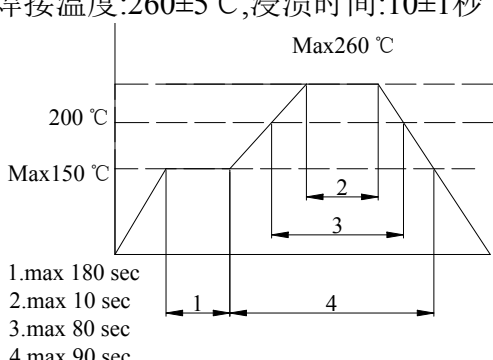
序号	RELIABILITY	RELIABILITY CONDITIONS	SPECIFICATION
	试验名称	可靠度试验条件	规格说明
1	ELECTRODE TERMINAL PULL 电极端子拉力	1KG FORCE IN AXES OF ELECTRODE TERMINATION 10±1sec 1KG力垂直施于电极端子上10±1秒	1.GLASS HERMETICITY & VISUAL. 玻璃密封性和外观检查
2	ELECTRODE WIRE-LEAD BEND 电极端子弯曲拉力	2.5mm FROM ELECTRODE TERMINAL,BEND 90°, 0.45kg MASS APPLIED 3TIMES. 2.5毫米处电极端子弯曲 90°	2. LEAD CRACKED or BROKEN NOT ALLOWED' 不允许引线断裂或破裂
3	SOLDERABILITY 产品可焊性	SOLDER:235±5°C,DIPPING:5±0.5sec. 焊接温度:235±5°C,浸渍时间:5±0.5秒	AT LEAST 95% COATING. 至少覆盖率为95%
4	RESISTANCE TO 产品可焊耐热时间	SOLDER:260+5°C,DIPPING:10±1sec. 焊接温度:260±5°C,浸渍时间:10±1秒  1.max 180 sec 2.max 10 sec 3.max 80 sec 4.max 90 sec	1.AT LEAST 95% COATING. 至少覆盖率为95% 2.ΔF/F≤±5ppm ΔF/Rr≤±10% or 2Ω BETTER,20%
5	VIBRATION TEST 振动测试	10g,10~55~10hz 1MINUTE,X、Y、Z PLANE EACH 2hrs. 10G, 10~55~10赫兹 1分钟,X、Y、Z 水平面,每2小时	ΔF/F≤±5ppm ΔF/Rr≤±10% or 2Ω BETTER,20%
6	DROP TEST 跌落测试	75CM HIGH,3 TIMES ON HARD BOARD 75厘米高, 3次坠落在硬木质板上	ΔF/F≤±5ppm ΔF/Rr≤±10% Oor 2Ω BETTER,20%
7	AGING TEST 老化测试	85°C Dynamic 1000hrs 85°C 动态测试1000小时	ΔF/F≤±5ppm ΔF/Rr≤±10% or 2Ω BETTER,20%
8	CCELERATED AGING 加速老化测试	125°C±3°C, TIME:168 hrs. Dynamic 125°C ± 3°C, 的动态下:168小时.	ΔF/F≤±5ppm ΔF/Rr≤±10% or 2Ω BETTER,20%

9	SALT SPRAY 盐水喷雾试验	5% NaCl 35°C±2°C CHAMBER,48hrs.PH:6.5~7.2	1.NO CORROSION ON LEAD&CAN1. 基座和外壳无腐蚀
		5% NaCl(碳酸钠),35°C±2°C的温箱里,48小时 PH值:6.5~7.2	△F/F≤±5ppm △F/Rr≤±10% or 2Ω BETTER,20%
10	HIGH-LOW TEM.STORAGE(STATIC	HIGH TEM:125°C±2°C,1000hrs LOW TEM:- 40°C±3°C,1000hrs 高	△F/F≤±5ppm
	STORAGE(STATIC) 高低温储存(静态测试)	LOW TEM:-40°C±3°C,1000hrs 低温:-40°C±3°C,1000小时	△F/Rr≤±10% or 2Ω BETTER,20%
11	HIGH TEM. & HUM. STORAGE TEST 高温高湿储存试验	TEM:40°C±2°C HUM:83%-88%,96hrs 温度:40°C±2 湿度:83%-88% ,储存96小时	△F/F≤±5ppm △F/Rr≤±10% or 2Ω BETTER,20%
	TEM. & HUM. CYCLING TEST 温湿度循环测试	TEM:-10°C±2°C ~65°C±2°C 24hrs 1 cycle' HUM:93±3% 5 cycles 温度:-10°C±2°C~65°C±2°C,湿度:93±3%, 24小时为1循环, 运行5个循环	△F/F≤±5ppm △F/Rr≤±10% or 2Ω BETTER,20%
13	HIGH-LOW TEM.OPERATING TEST 高-低温运行测试	HIGH TEM:70°C±2°C,2hrs LOW TEM:-20°C ±2°C,2hrs 高温:70°C±2	△F/F≤±5ppm △F/Rr≤±10% or 2Ω BETTER,20%
	FREQUENCY/Rr V.S OPERATING TEM.. 频率/电阻在操作温度下之变化测试	TEM:-10°C ~+60°C、-20°C ~+70°C、 0°C ~70°C 'MEASURE POINT: EVERY 10°C DEVIATION. 温度:-10°C~+60°C、-20°C~+70°C 0°C~70°C	AS SPECIFICATION 依客户要求

